

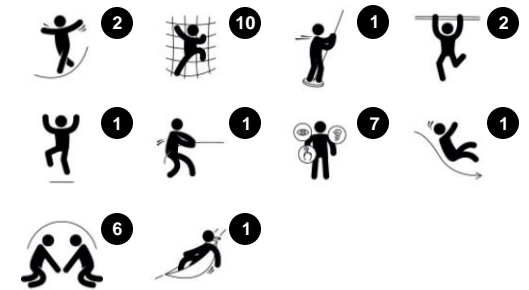

Item no. NAT520-0901

General Product Information

Dimensions LxWxH	305x768x545 cm
Age group	4+
Play capacity (users)	14
Colour options	



The Amazon is a challenging climbing structure with a high tube slide and an imaginative explorer theme and a meeting place under deck. The structure supports the child's agility, balance and coordination.

Amazon

NAT520



Highly durable FSC® Certified (FSC® C004450) hardwood from sustainable sources. The hardwood has a density of app. 1.050 kg/m³ and is located in durability class 1. It has an expected lifetime in outdoor environment without any preservation of 25-50 years depending on local locations.



Panels of 19mm EcoCore™. EcoCore™ is a highly durable, eco friendly material, which is not only recyclable after use, but also consists of a core produced from 100% recycled material.



The slide is made of high quality stainless steel AISI 304. The steel is cleaned by a total pickling process after manufacturing to ensure a smooth and clean gliding surfaces.

Item no. NAT520-0901	
Installation Information	
Max. fall height	287 cm
Safety surfacing area	46.0 m ²
Numbers of installers (persons)	2
Total installation time	28.5
Excavation volume	2.44 m ³
Concrete volume	0.10 m ³
Footing depth (standard)	92 cm
Shipment weight	1,280 kg
Anchoring options	In-ground ✓ Surface ✓
Warranty Information	
Hardwood	10 years
EcoCore HDPE	Lifetime
Stainless steel slide	10 years
Ropes & nets	5 years
Spare parts guaranteed	10 years



Nets and ropes are made of UV-stabilised PA with inner steel cable reinforcement. The rope is induction treated in order to create a strong connection between steel and rope which leads to good wear resistance.



The steel surfaces are hot dip galvanised inside and outside with lead free zinc. The galvanisation has excellent corrosion resistance in outside environments and requires low maintenance.



Roof is made of a steel frame supported Ekogrip® panel. The Ekogrip® panel consist of a 15mm thick PE base with 3 mm top-layer of rubber.



* Max fall height | ** Total height | *** Safety surfacing area

* Max fall height | ** Total height

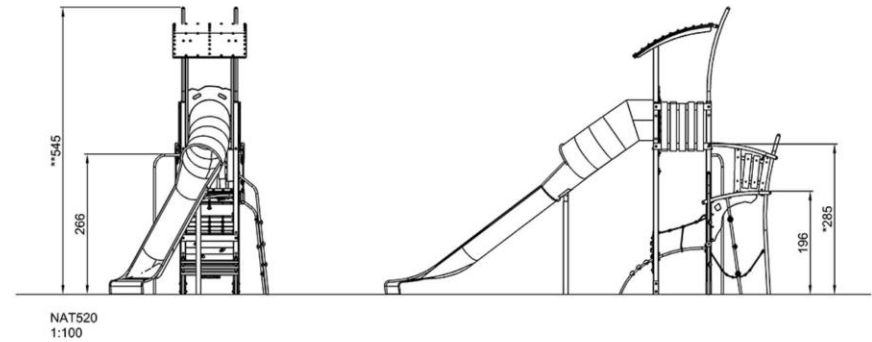
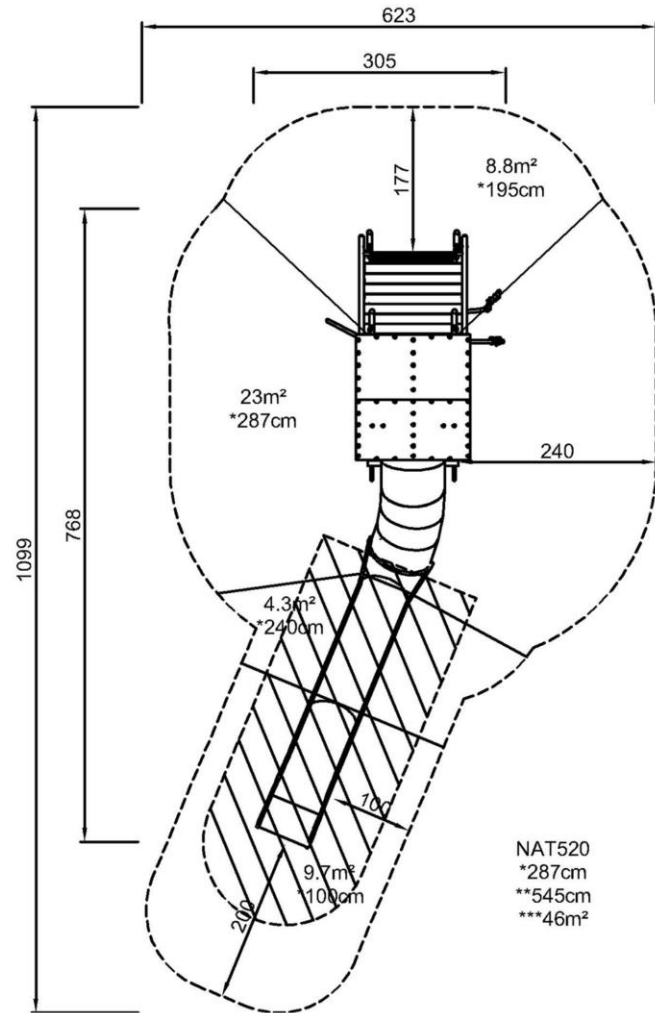

[Click to see 1:100 ratio TOP VIEW](#)



Fireman's pole

Physical: coordination is supported when going down, as well as arm and core muscles. Landing strengthens bone density, which is built for life in early childhood.

Social-Emotional: turn-taking and risk-taking.

Cognitive: young children develop their understanding of space, speed and distances when gliding down fast.



Slide

Physical: sliding develops spatial awareness and a sense of balance. Furthermore, the core muscles are trained when sitting upright going down.

Social-Emotional: empathy stimulated by turn-taking.

Cognitive: young children develop their understanding of space, speed and distances when sliding down quickly.

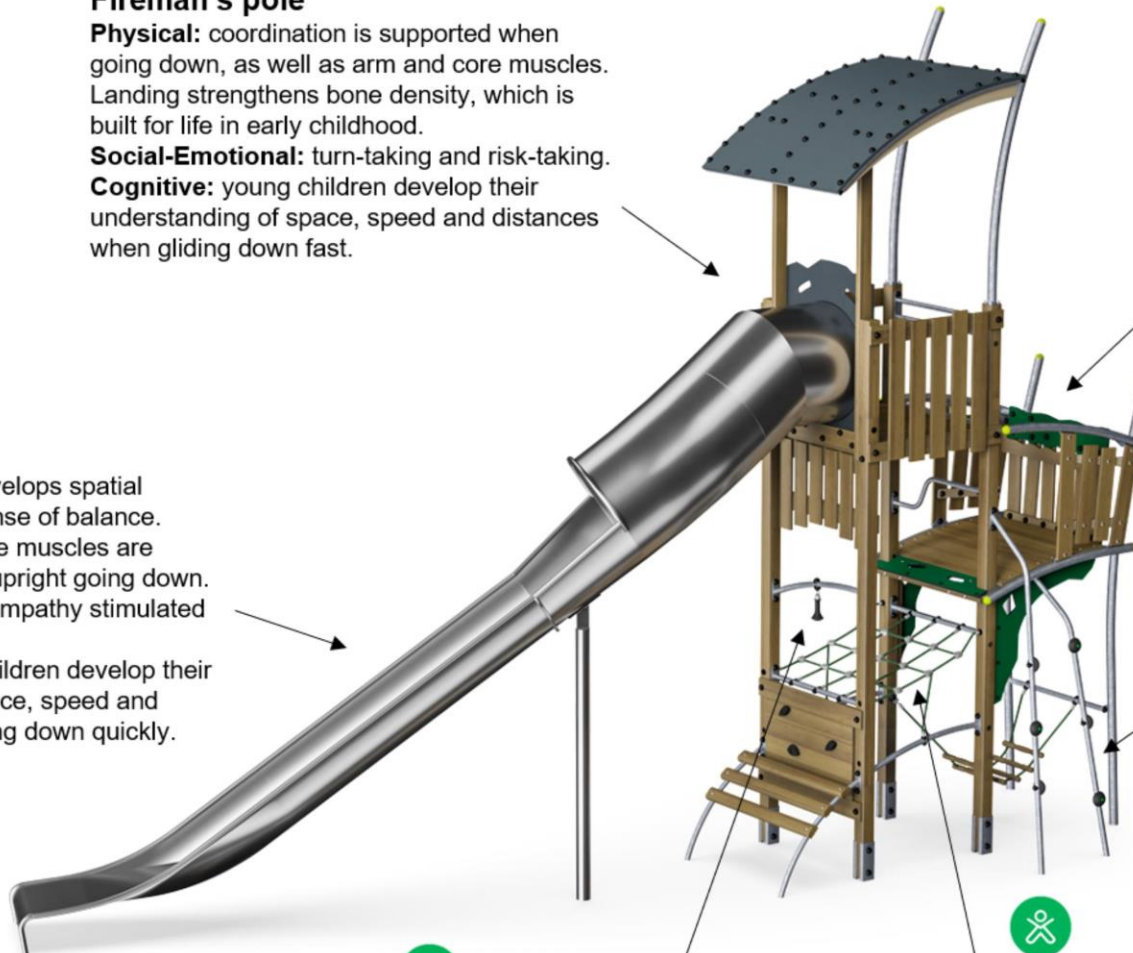

Platform

Social-Emotional: the platform allows for more children to be together and share. Important life skills like courage, self-confidence, consideration and turn-taking are built.



Climbing pole

Physical: develops children's cross coordination, eye-hand coordination and muscle strength when climbing up or down.

Social-Emotional: turn-taking and self-regulation are trained, both important life skills.



Teardrop handle

Physical: develop upper body muscles, when e.g. pulling yourself up or hanging in your arms.



Climbing net

Physical: the net allows for climbing around, which supports motor skills, proprioception and spatial awareness. Children use muscle strength of arms, legs, and core when climbing.



PHYSICAL
Joy of movement:
motor skills, muscle, cardio
and bone density



SOCIAL-EMOTIONAL
Joy of being together:
teamwork, tolerance and
sense of belonging



COGNITIVE
Joy of learning:
curiosity, understanding of causal
relationships and knowledge of the world



CREATIVE
Joy of creating:
co-creation and experimenting
with materials



BALANCE
To balance is to stay upright when walking or standing on a surface that makes this challenging (e.g. a wobbly, inclined, or narrow surface).



HANG IN ARMS
To hang in arms is the act of carrying the body with the hands or arms, possibly to traverse to another platform or play item.



SENSORY
To sense is the act of taking in information with the sensory system: seeing, feeling, hearing or sensing with the body.



BOUNCE
To bounce is the act of bouncing on a responsive, flexible, elastic or tensile surface.



JUMP
To jump is the act of jumping up or down on a hard surface.



SLIDE
To slide is the act of moving fast downwards seated on a slide.



CLIMB
To climb is the act of moving upwards, cross-coordinating arms and legs, on a vertical or inclined surface or net.



PULL
To pull is the act of pulling an item towards you or you towards an item with one or both hands, or possibly using the entire body.



SOCIALIZE
To socialize is the act of meeting, communicating or cooperating in an activity that stimulates and facilitates social interaction.



CONSTRUCT
To construct is the act of creating new patterns, shifting items or materials to new positions or constructing with materials that can be transformed or manipulated.



PUSH
To push is the act of pushing an item away from you with one or both hands, possibly with the entire body.



SPIN
To spin involves a fast, repeated horizontal or vertical turn of the body on a piece of equipment that facilitates the movement.



CRAWL
To crawl is the movement of moving forwards or backwards, cross-coordinating arms and legs, on a horizontal or slightly inclined surface.



ROCK
To rock is the action of rocking back and forth, or sideways, on e.g. a piece of spring equipment.



SWAY
To sway is the movement of swaying back and forth, or around, lying, seated or possibly standing, in a pendulant or circular movement, e.g. on a hammock or on a rope.



DRAMATIC PLAY
Dramatic play is motivated through play items that stage a frame, place or environment for acting out make believe or role play scenarios.



ROTATE
To rotate involves a vertical or horizontal slower paced turn of the body, facilitated by a piece of equipment.



SWING
To swing is the movement of swinging back and forth, or in circular movement, seated, standing or lying, in an unhindered arc.



GLIDE
To glide is the act of moving from one point to another without shifting the feet, in a horizontal or vertical movement, in a seated, lying or standing position, letting gravity do the work.



RULES PLAY
Rules play is motivated through play items that suggest games-with-rules, cooperation and team work, e.g. tic-tac-toe, timers or ball games.



WONDER
To wonder is motivated through play items that make children need and use their logical, abstract or creative thinking skills, as well as their memory.